

Space, shape and Measures 2

virtual image, numeracy lesson starters, menu 5, capacity

Reading scales

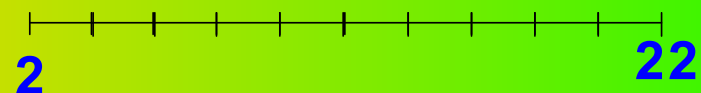
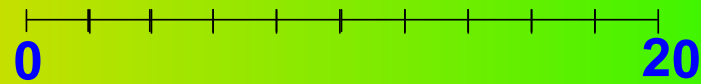
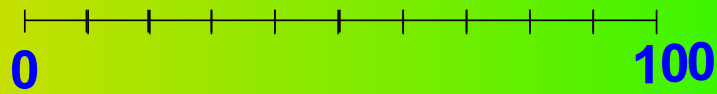
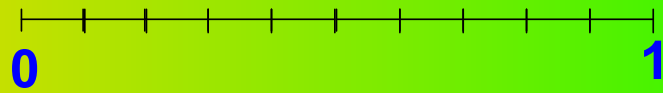
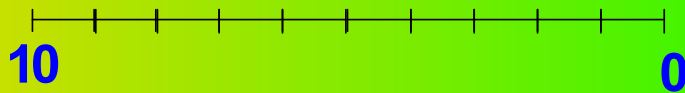
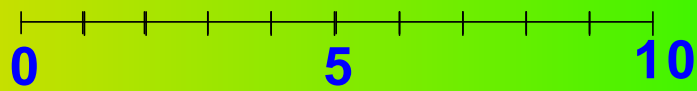

Estimating worksheet www, mathematical starters

Matching Pairs

Some of the scales below have the same readings. Find 4 pairs.

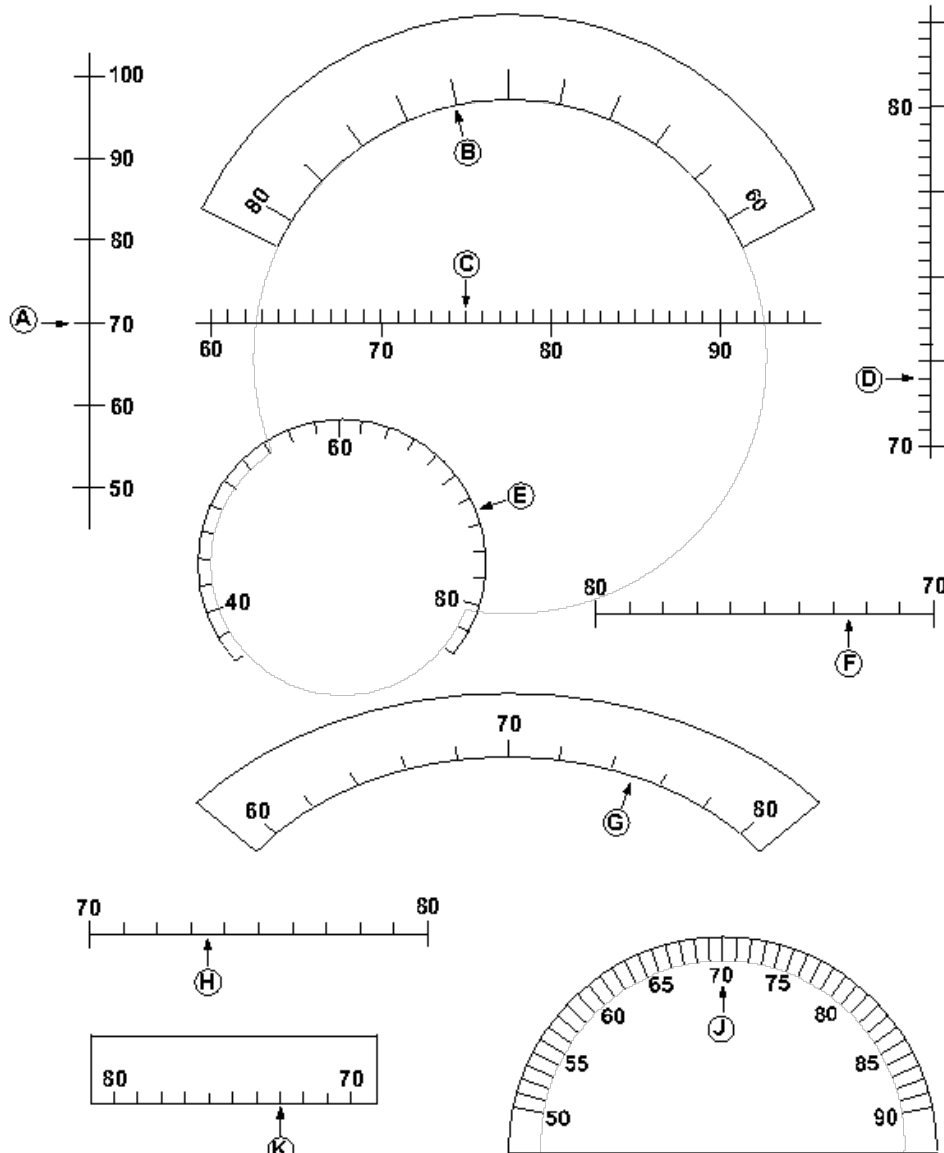

The 4 matching pairs are:

© RSKC SMILE 2001

Converting between metric and Imperial Units

Units to measure length:

metric	imperial
millimetres	inch
centimetres	feet
meters	yards
kilometres	miles

10 mm = 1 cm
100 cm = 1 m
1000 m = 1 km

12 inches = 1 foot
(3 feet = 1 yard)

common conversions:

1 inch = 2.5 cm
1.6 km = 1 mile
1600 m

$\frac{5}{8}$ mile = 1 km

Estimate the height of Yohan

Actual:

Estimate the length of table

Actual:

Estimate the diameter of the sharpener

Actual:

Units to measure weight:

metric	imperial
grams	ounces (oz)
kilograms	pounds (lb)
tonnes	stone
1000g = 1kg	tons
1000 kg = 1 tonne	16oz = 1 lb
	14 lb = 1 stone

common conversions:

100g = 4 ounces

two and a quarter pounds of Jam weigh about a kilogram

Estimate the weight of Albin

Actual:

Estimate the weight of a rubber:

Actual:

Estimate the weight of a chair:

Actual:

Measuring Time.

Estimating 30 seconds

quiz



bus timetable

Money!

Estimate the cost of :

a small house for a family of four

a library of books

A week's food for a family of four

a goal post for rugby

the salary of a shopworker

Can you estimate:

Estimation Game Interface

Buttons: Edit, Reset, Check, ?

The population of Great Britain	The age of Mr Matthews	The time for a 100 metre sprint	Today's weather
A healthy body temperature	The cost of a family house in Cambridge	The cost of a weekly food shop	The world population

Estimate the distance from Cambridge to...

Ely

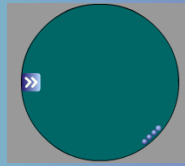

London



Edinburgh



Paris

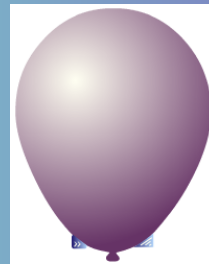

Singapore

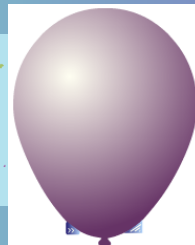

Cambridge	to...
Thailand	
Gateshead	

Estimate the length of..

your little finger



your pencil



your desk



you



the door



Estimating Lengths

item	estimate	actual length
my pencil		
a ruler		
my desk		

Choose two items of your own to add on.

Estimating Weights

item	estimate	actual length
my pencil		
a rubber		
my chair		

Choose two items of your own to add on.

True or
false?

The surface
area of a cuboid
is 6x the area of
one face.

One kilometre is less than one mile.

If you work out the area and
perimeter of a rectangle, the
number for the area is always
greater than the number for the
perimeter.

$1000\text{cm}^3 = 1 \text{ litre}$

Drawing 3D shapes

Hint: make sure your paper is the right way up!

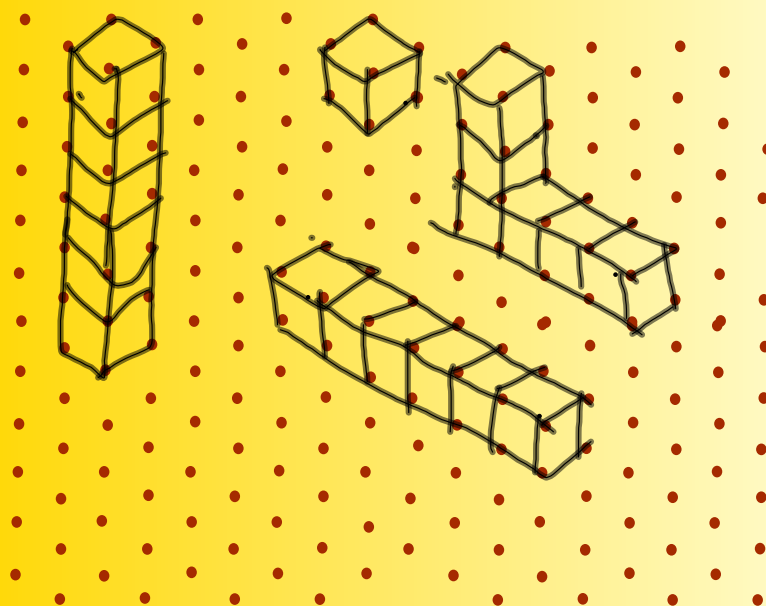

Draw as many 3D models as you can with 4 cubes.

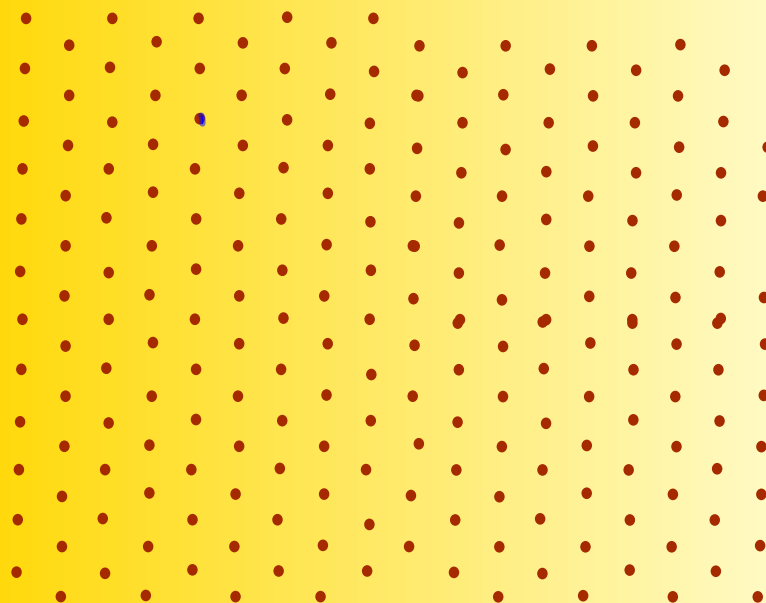

Make a cuboid with 6 cubes.

Draw it.

Now make a different one and draw it.

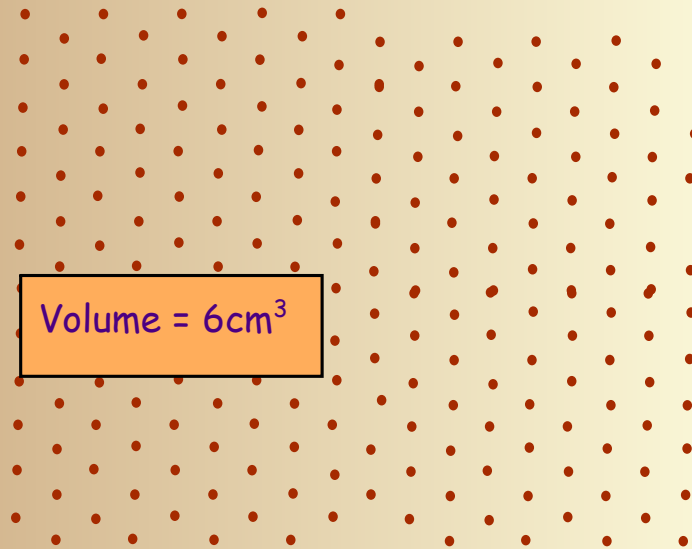

Make a cuboid with 8 cubes.

Draw it.

Now make a different one and draw it.

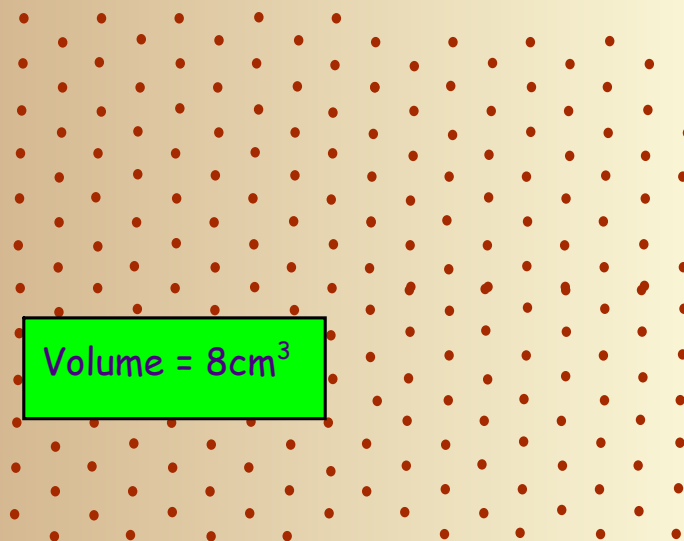

Make cuboids with volume 12cm³ and draw them.

(There are loads of different ones)

Volume

Find the volume of each shape:

<u>Colour</u>	<u>Volume</u>
pink	80 cm^3
white	32 cm^3
d green	45 cm^3
l green	24 cm^3
red	70 cm^3
orange	36 cm^3
yellow	64 cm^3
black	72 cm^3
brown	48 cm^3
mixed	26 cm^3
or & gr	56 cm^3
bl & gr	40 cm^3
blue	18 cm^3

Volume of a cuboid

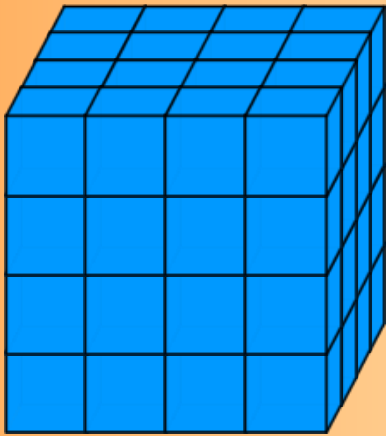

Volume=

$$4 \times 4 \times 4 = 64 \text{ cm}^3$$

Volume = length \times width \times depth

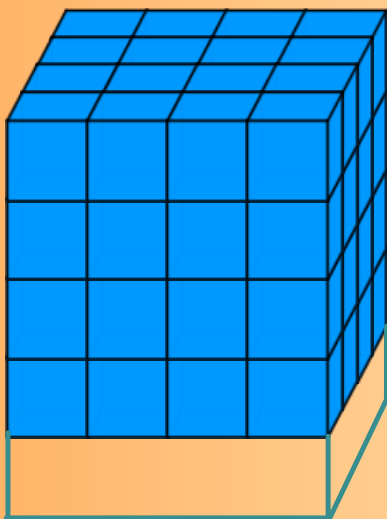

Volume=

Finding the volume of cuboids

Volume of a cuboid = length \times width \times height

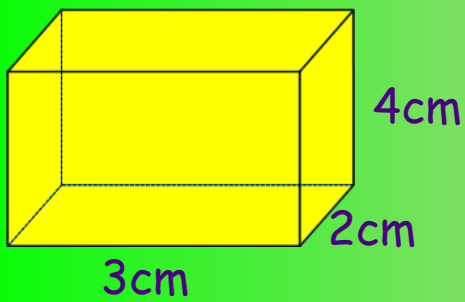

Volume =

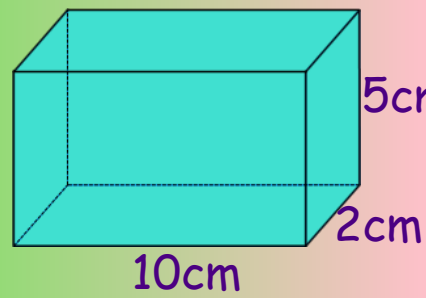

2) Volume =

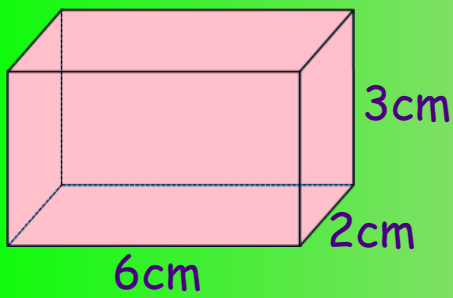

Volume =

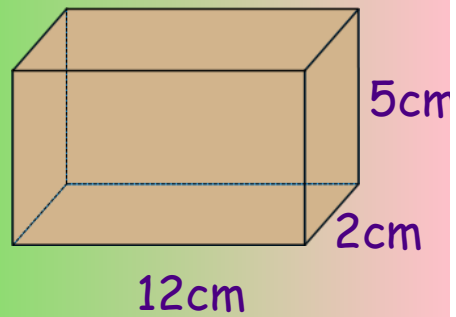

Volume =

A cuboid has volume 60cm^3 .
What dimensions might it have?

Draw the net of a cuboid.

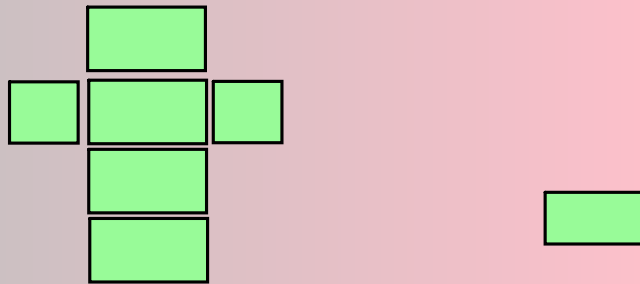

Design a cuboid with volume 60cm^3 .



Play

Reset

Print

Packaging Explorer

Finding the volume of boxes

We are going to find the volume of some boxes by measuring and applying the formula.

Copy the table into your book:

box	length x width x height	volume
white box	3.4 x 5.7 x 6.8	? cm ³

• Use units of measurement to estimate, calculate and solve problems in everyday contexts involving length, area, volume, capacity, mass, time and angle; know rough metric equivalents of imperial measures in daily use (feet, miles, pounds, pints, gallons).

• Deduce and use formulae for the area of a triangle, parallelogram and trapezium; calculate areas of compound shapes made from rectangles and triangles.

• Know and use the formula for the volume of a cuboid; calculate volumes and surface areas of cuboids and shapes made from cuboids.

• Investigate in a range of contexts: measures.

Attachments

metric and imp units.ppt

area_compound_shapes.odt